

The Harman Kardon Model HK610 INTEGRATED AMPLIFIER

Manual 196A

Technical Manual

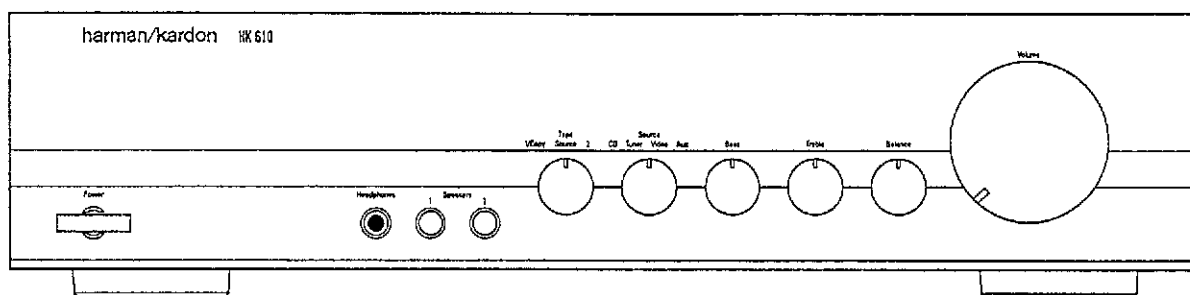

The following marks found in the parts list of this manual identify the models as follows:

- IB** : International model Black version
- I** : International model

CONTENTS

SPECIFICATIONS.....	2	WIRING DIAGRAM.....	12
DISASSEMBLY PROCEDURES.....	2	SCHEMATIC DIAGRAM.....	13
BLOCK DIAGRAM.....	2	PH600 PHONO P.C.BOARD OPTION	
CONTROLS AND FUNCTIONS.....	3	HOW TO INSTALL.....	15
ALIGNMENT PROCEDURES.....	4	GENERAL UNIT PARTS LIST.....	15
GENERAL UNIT PARTS LIST.....	4	P.C.BOARD.....	16
GENERAL UNIT.....	5	WIRING DIAGRAM.....	16
P.C.BOARDS.....	6	SCHEMATIC DIAGRAM.....	17
ELECTRICAL PARTS LIST.....	8	ELECTRICAL PARTS LIST.....	18

harman/kardon

Parts and Service Office
80 Crossways Park West, Woodbury, N.Y. 11797
1112-HK610-A A9502 300 Printed in Japan

SPECIFICATIONS

	Nominal	Limit		Nominal	Limit
RMS Output Power			Damping Factor (at 1Hz):	106	≥ 90
8 Ω, 1kHz THD 0.1%	41.5W	≥ 30W	Phono-Overload		
4 Ω, 1kHz THD 0.3%	57W	≥ 45W	Option Phono (MM):	109mV	
High-Instantaneous Current			Option Phono (MC):	5.6mV	
Capability (HCC)	34A	≥ 20A	Tone Control Characteristics		
Half Power Bandwidth (THD 0.1%)	<10Hz-73kHz	<10Hz-50kHz	Bass (at 50Hz)	Boost	10dB ± 2dB
Frequency Response				Cut	10dB ± 2dB
(at -3dB down)	0.4Hz-110kHz	<1Hz- ≥ 80kHz	Treble (at 10kHz)	Boost	10dB ± 2dB
Input Sensitivity				Cut	10dB ± 2dB
(at 30W output) Tuner/CD:	135mV	>135mV ± 35mV/17kΩ ± 5kΩ	DC Output Voltage (at 8Ω)		
Option Phono (MM):	2.4mV/49kohm		L channel	0mV ± 60mV	
Option Phono (MC):	131μV/56Ω		R channel	0mV ± 60mV	
Signal to Noise Ratio			Idling Current (at 8Ω)	75mA ± 5mA	
Tuner/CD:	88dB	≥ 75dB	Dimension	17.4" × 4.1" × 14.1"	
Option Phono (MM):	79dB		(W × H × D)	(443 × 104 × 359 mm)	
Option Phono (MC):	75dB		Weight	14.3 lbs./6.5kg	
Channel Separation (at 10kHz):	69dB	≥ 45dB	Power Supply	AC 230V, 50/60Hz	
Option Phono (MM):	65dB		Power Consumption	150W	
Option Phono (MC):	65dB				
IM Distortion Ratio (at 1W):	0.025%	≤ 0.1%			

These specifications are service target specs.

Specifications and components are subject to change without notice. Overall performance will be maintained or improved.

DISASSEMBLY PROCEDURES (REFER TO PAGES 5 AND 12)

1 CABINET TOP (131) REMOVAL

Remove 6 screws (A) and then remove the Cabinet Top (131).

2 FRONT PANEL ASS'Y (AA) REMOVAL

1. Pull out 5 Rotary Knobs (151).
2. Remove the Cabinet Top (131), referring to the previous step 1.
3. Remove 5 screws (B) and then remove the Front Panel Ass'y (AA).

3 MAIN P.C. BOARD (PCB-1) REMOVAL

1. Remove the Front Panel Ass'y (AA), referring to the previous step 2.
2. Remove the Rotary Knob (150) and remove the 2 Push Buttons (146).
3. Remove 6 hexagon nut (C) and then remove the VR P.C. Board (PCB-9).

4. Disconnect the 1 connector (CW91) from 1 connector (CN91) on the Main P.C. Board (PCB-1).
5. Remove 8 screws (D) and then remove the Chassis (161).
6. Remove 11 screws (E) and then remove the Main P.C. Board (PCB-1).

4 OPTION PHONO P.C. BOARD (PCB-101) REMOVAL

1. Remove the Cabinet Top (131), referring to the previous step 1.
2. Remove 1 screw (199) and then disconnect 2 connectors (CW602 and W601) from 2 connectors (CN102 and CN101) on the Main P.C. Board (PCB-1).

BLOCK DIAGRAM

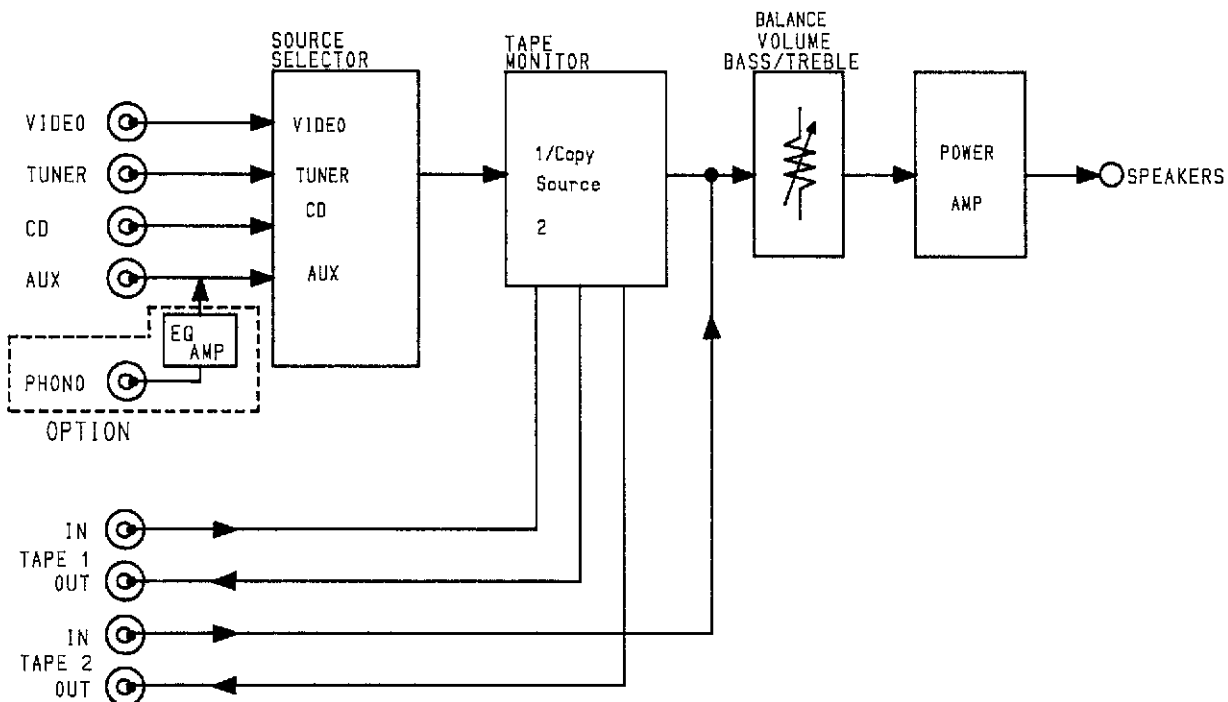

CONTROLS AND FUNCTIONS

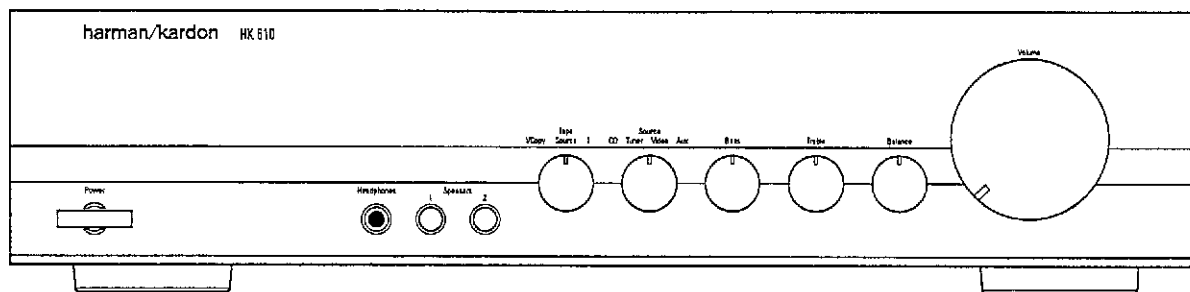

Power Switch

Press to turn the unit on and off.

Power Indicator

Indicates that the unit is switched on.

Headphone Jack

Plug in headphones if desired. (With both Speakers 1 and 2 switches in Off position, output is supplied only to headphones.)

Speakers Switches

Push in to select either of two sets of speakers, or both, or neither (headphone output only).

Tape Monitor Selector

This selector is used when playing a tape deck, or monitoring during recording.

1/Copy: Select this position to play a tape on the tape deck connected to the TAPE 1 jacks. This is also the position to use to copy a tape from Tape 1 to Tape 2.

Source: Select this position to listen to a program source other than a tape.

2: Select this position to play a tape, or to monitor during recording on the tape deck connected to the TAPE 2 jacks.

Source Selector

This selector is used to select a program source other than a tape.

CD: Select this position to listen to a CD player connected to the CD jacks.

Tuner: Select this position to listen to a Tuner connected to the TUNER jacks.

Video: Select this position to listen to the sound of a TV, VCR or Laserdisc player connected to the VIDEO jacks.

Aux: Select this position to listen to a source connected to the AUX jacks.

Bass Control

Turn to increase or decrease the proportion of low frequency sound.

Treble Control

Turn to increase or decrease the proportion of high frequency sound.

Balance Control

Turn to adjust relative output level of left and right speakers.

Volume Control

Turn to raise or lower output volume.

ALIGNMENT PROCEDURES (REFER TO PAGES 6 AND 13)

- **Conditions :**
 - Set the Source selector to the "CD" position.
 - Set the Volume control to minimum.
 - Make the adjustment at a room temperature of 77°F (25°C).

■ **DC BALANCE CONFIRMATION**

Step	Connection Equipments	Adjustment	For
1	Connect the Digital Volt Meter to Speaker output (L ch).		0 ± 60mV
2	Connect the Digital Volt Meter to Speaker output (R ch).		0 ± 60mV

■ **IDLING CURRENT ADJUSTMENT**

Step	Connection Equipments	Adjustment	For
1	Connect the Digital Volt Meter to TP401 and TP403.	VR401	7 ± 0.5mV
2	Connect the Digital Volt Meter to TP402 and TP404.	VR402	7 ± 0.5mV

- After the above adjustment, leave the unit with its power on for longer than 15 minutes and then repeat the same adjustment.

GENERAL UNIT PARTS LIST

Ref. No.	Part No.	Description	Ref. No.	Part No.	Description
AA	A443-HK6110A	FRONT PANEL ASSEMBLY (IB)	156	1742-09601	ORNAMENT, POWER BUTTON (I)
AA	A443-HK6110B	FRONT PANEL ASSEMBLY (I)	157	1742-09402	ORNAMENT, SPEAKER BUTTON (IB)
AB	A319-HK6110A	LEG ASSEMBLY (x4)	157	1742-09401	ORNAMENT, SPEAKER BUTTON (I)
118	1117-78	SERIAL LABEL	159	1319-04303	LEG (x4)
131	1414-17004	CABINET, TOP	160	1319-04601	LEG, SPONGE (x4)
133	1424-38501	CABINET BACK, BOTTOM	161	2211-7331	CHASSIS
135	1424-38604	CABINET BACK, REAR	166	2219-8425	METAL FITTG, HEAT SINK
137	1443-15401	FRONT PANEL (IB)	167	2219-2576	METAL FITTG, CABINET BOTTOM
137	1443-15402	FRONT PANEL (I)	170	2216-7210	SHIELD PLATE
140	1562-09802	FRAME, L (IB)	173	2222-7344	HEAT SINK
140	1562-09801	FRAME, L (I)	176	2224-7134	INSULATOR, POWER Tr (x4)
141	1562-09902	FRAME, R (IB)	179	2360-7021	BOSS, SPE, MAIN PCB (x2)
141	1562-09901	FRAME, R (I)	183	2402-0374	WASHER, PLASTIC, HEAT SINK REAR (x2)
144	1511-23601	PLATE, EQ	184	2402-0374	WASHER, PLASTIC (x3)
146	1662-67202	PUSH BUTTON, SPEAKER (x2) (IB)	185	2459-3003511	RIVET, PLASTIC, EQ PLATE
146	1662-67201	PUSH BUTTON, SPEAKER (x2) (I)	188	2240-R0101	HOLDER, WIRING (x19)
147	1662-72002	PUSH BUTTON, POWER (IB)	190	2218-R0130	BRACKET, FIX (x2)
147	1662-72001	PUSH BUTTON, POWER (I)	191	2459-3004511	RIVET, PLASTIC (x8)
150	1630-05102	ROTARY KNOB, VOLUME (IB)	193	2327-R0130062	SCREW, BND+ (3x6 mm) (x4)
150	1630-05101	ROTARY KNOB, VOLUME (I)	197	2347-R0130082	SCREW, BND+ (3x8 mm) (x21)
151	1632-20702	ROTARY KNOB, BASS/TRE/BAL/ SOURCE/TAPE (x5) (IB)	199	2347-R0130084	SCREW, BND T+ (3x8 mm) (x17)
151	1632-20701	ROTARY KNOB, BASS/TRE/BAL/ SOURCE/TAPE (x5) (I)	202	2347-R0130202	SCREW, BND T+ (3x20 mm) (x2)
153	1732-09701	INDICATOR, POWER (x2)	203	2347-R0140082	SCREW, BND T+ (4x8 mm) (x4)
156	1742-09602	ORNAMENT, POWER BUTTON (IB)	204	2347-R0140064	SCREW, BND T+ (4x6 mm) (x4)
			210	2557-F301426	SCREW, B SPW+ (3x14 mm) (x10)

GENERAL UNIT
EXPLODED VIEW

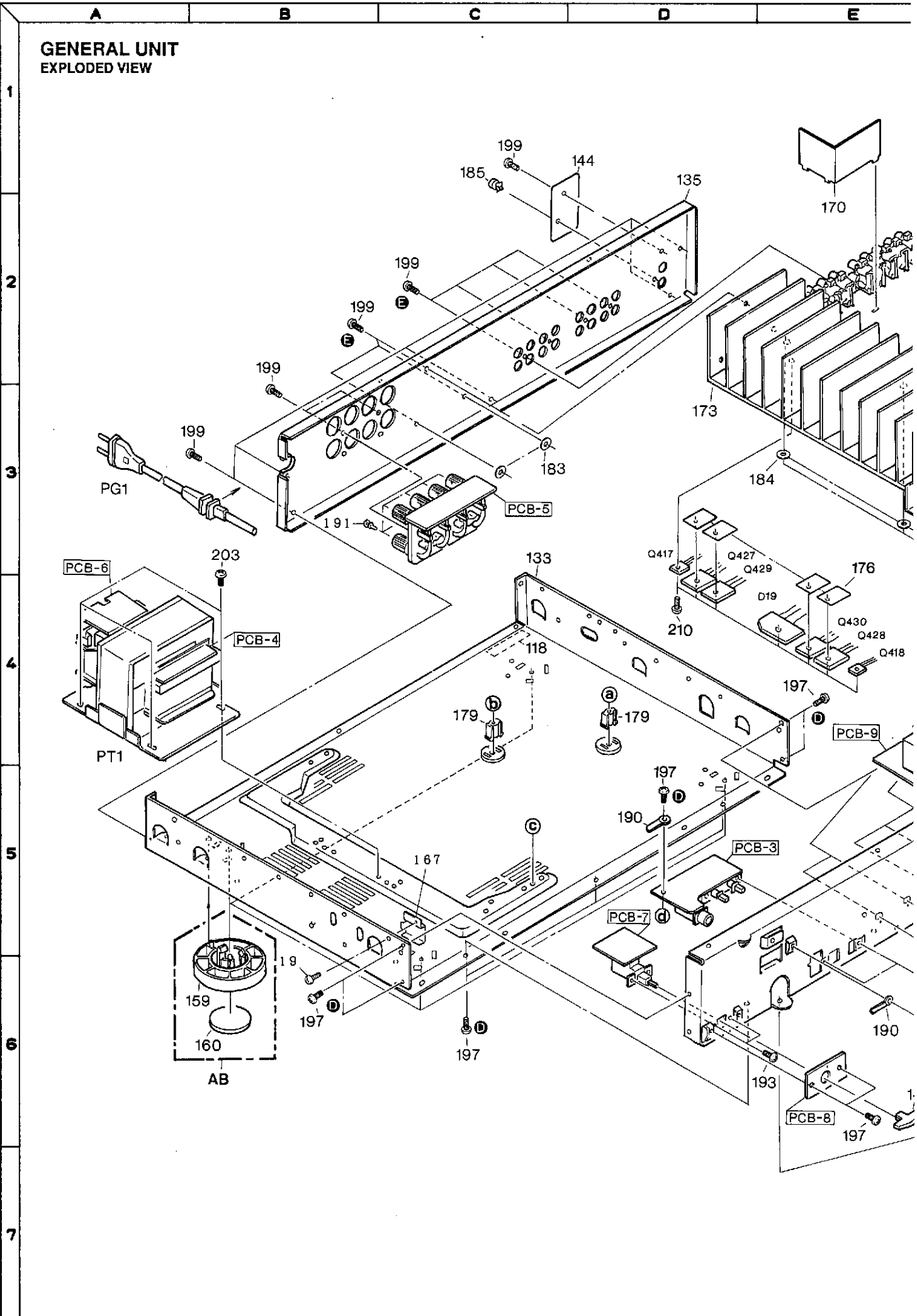

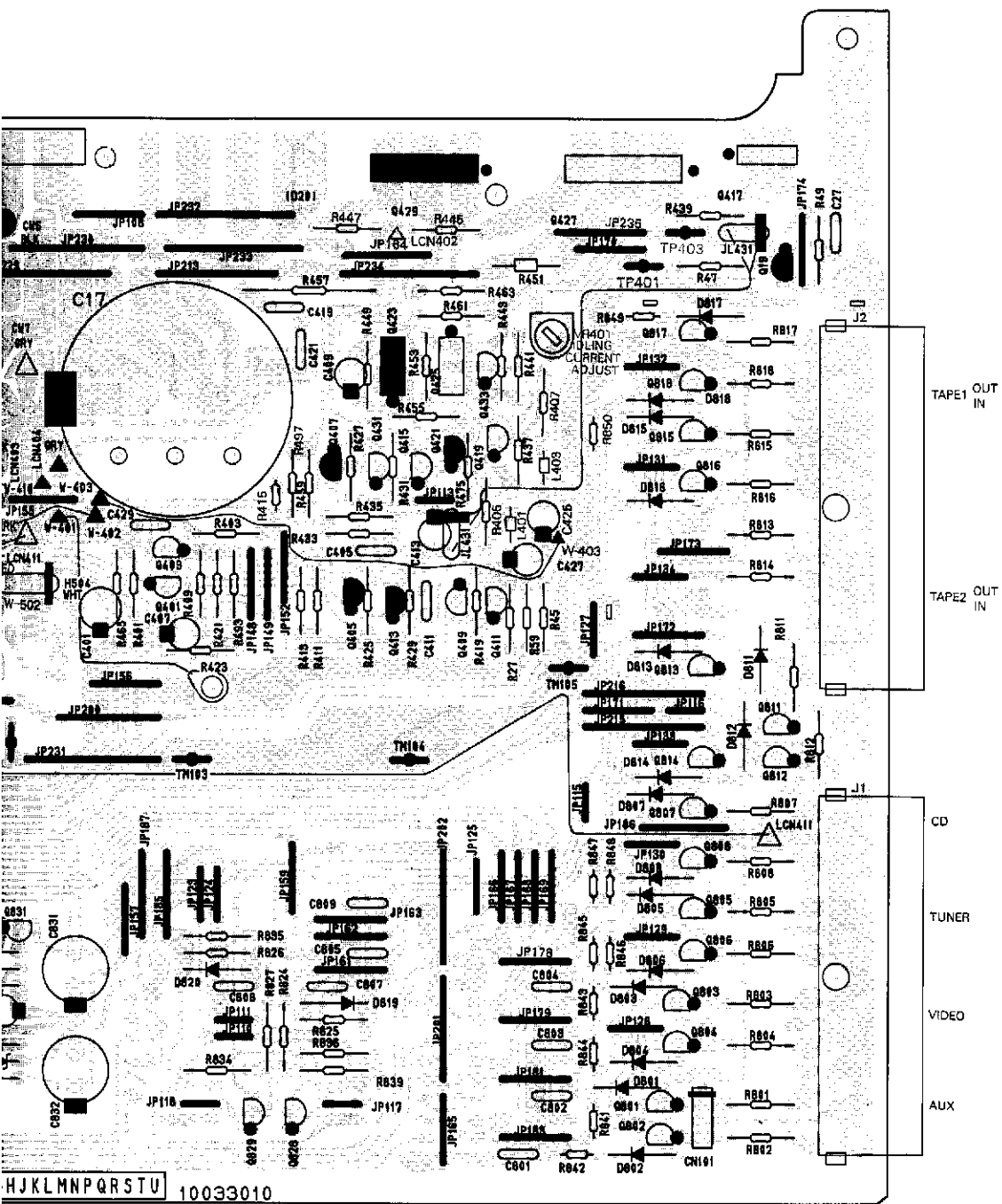

TAPE1 OUT IN
 TAPE2 OUT IN
 CD
 TUNER
 VIDEO
 AUX

HJKLMNPQRSTU 10033010

SP TERMINAL P.C.BOARD

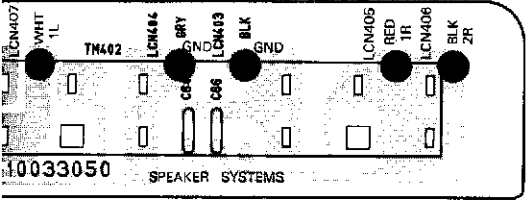

10033050 SPEAKER SYSTEMS

P.C. BOARDS

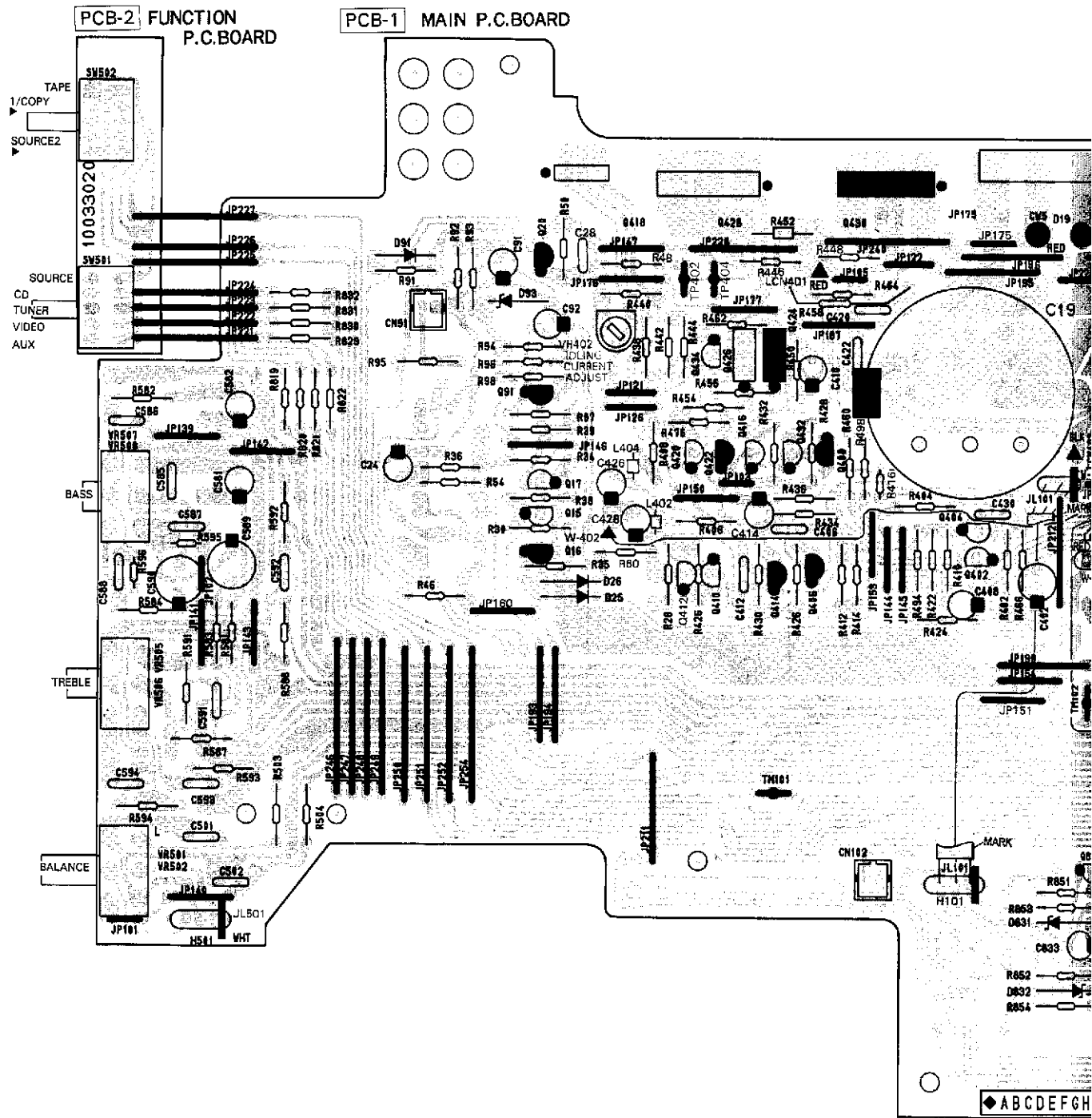

PCB-3 SP SW P.C. BOARD

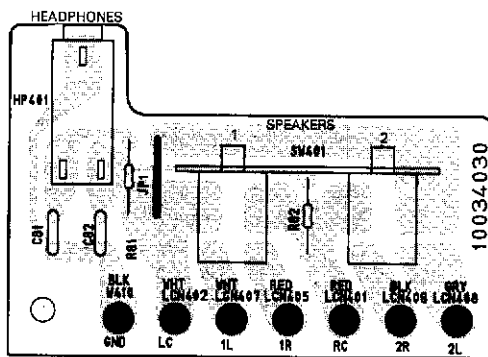

PCB-4 SECOND P.C. BOARD



PCB-5 SP



A B C D E

P.C. BOARDS

1

PCB-6 PR P.C.BOARD

PCB-7 POWER SW P.C.BOARD

2

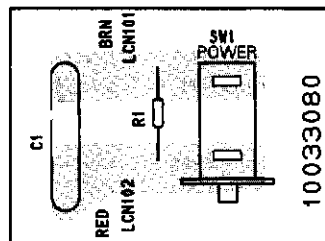
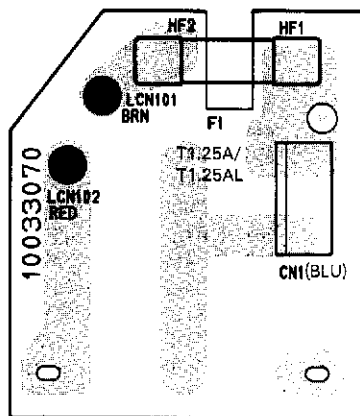

3

4

PCB-8 POWER IND P.C.BOARD

PCB-9 VR P.C.BOARD

5

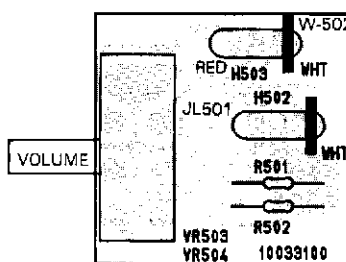
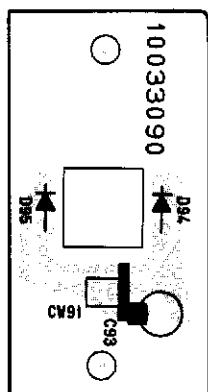

6

7

ELECTRICAL PARTS LIST

Ser. No.	Ref. No.	Part No.	Description	Ser. No.	Ref. No.	Part No.	Description
PCB-1 MAIN P.C. BOARD							
CAPACITORS							
724	C17	5341-S45FM109	CAP, ELE 10000U/43V	711	R50	5134-821J25P	RES, CBN 1/4P 820
724	C19	5341-S45FM109	CAP, ELE 10000U/43V	703	R54	5134-223J25P	RES, CBN 1/4P 22K
691	C24	5345-334F0962	CAP, MINI ELE .33U/50V	712	R59	5134-123J25P	RES, CBN 1/4P 12K
692	C27	5354-124593	CAP, MYL .12U	712	R60	5134-123J25P	RES, CBN 1/4P 12K
692	C28	5354-124593	CAP, MYL .12U	708	△ R91	5102-8215116	RES, FUSE 820
716	C91	5345-106F0962	CAP, MINI ELE 10U/50V	704	R92	5134-103J25P	RES, CBN 1/4P 10K
694	C92	5345-107A0962	CAP, MINI ELE 100U/6.3V	715	R93	5134-822J25P	RES, CBN 1/4P 8.2K
601	C401	5345-227A0962	CAP, MINI ELE 220U/6.3V	714	R94	5134-124J25P	RES, CBN 1/4P 120K
601	C402	5345-227A0962	CAP, MINI ELE 220U/6.3V	713	R95	5134-222J25P	RES, CBN 1/4P 2.2K
602	C405	5361-020DSL	CAP, CER 2P	707	R96	5134-472J25P	RES, CBN 1/4P 4.7K
602	C406	5361-020DSL	CAP, CER 2P	703	R97	5134-223J25P	RES, CBN 1/4P 22K
603	C407	5345-337A0962	CAP, MINI ELE 330U/6.3V	701	R98	5134-472J25P	RES, CBN 1/4P 4.7K
603	C408	5345-337A0962	CAP, MINI ELE 330U/6.3V	631	R401	5134-683J25P	RES, CBN 1/4P 68K
607	C409	5345-106F0962	CAP, MINI ELE 10U/50V	631	R402	5134-683J25P	RES, CBN 1/4P 68K
607	C410	5345-106F0962	CAP, MINI ELE 10U/50V	627	R403	5134-562J25P	RES, CBN 1/4P 5.6K
606	C411	5361-070DSL	CAP, CER 7P	627	R404	5134-562J25P	RES, CBN 1/4P 5.6K
606	C412	5361-070DSL	CAP, CER 7P	628	△ R405	5102-3R35116	RES, FUSE 3.3
604	C413	5345-106C0962	CAP, MINI ELE 10U/16V	628	△ R406	5102-3R35116	RES, FUSE 3.3
604	C414	5345-106C0962	CAP, MINI ELE 10U/16V	628	△ R407	5102-3R35116	RES, FUSE 3.3
605	C419	5354-224593	CAP, MYL .22U	628	△ R408	5102-3R35116	RES, FUSE 3.3
605	C420	5354-224593	CAP, MYL .22U	633	R409	5134-473J25P	RES, CBN 1/4P 47K
605	C421	5354-224593	CAP, MYL .22U	633	R410	5134-473J25P	RES, CBN 1/4P 47K
605	C422	5354-224593	CAP, MYL .22U	634	△ R411	5102-1025116	RES, FUSE 1K
608	C425	5345-105F0962	CAP, MINI ELE 1U/50V	634	△ R412	5102-1025116	RES, FUSE 1K
608	C426	5345-105F0962	CAP, MINI ELE 1U/50V	632	△ R413	5102-1024715	RES, FUSE 1K
608	C427	5345-105F0962	CAP, MINI ELE 1U/50V	632	△ R414	5102-1024715	RES, FUSE 1K
608	C428	5345-105F0962	CAP, MINI ELE 1U/50V	629	△ R415	5102-S081J470	RES, FUSE 47
610	C429	5359-S010K221	CAP, PPP 220P	629	△ R416	5102-S081J470	RES, FUSE 47
610	C430	5359-S010K221	CAP, PPP 220P	635	R419	5134-271J25P	RES, CBN 1/4P 270
670	C501	5359-S010K471	CAP, PPP 470P	635	R420	5134-271J25P	RES, CBN 1/4P 270
670	C502	5359-S010K471	CAP, PPP 470P	636	R421	5134-224J25P	RES, CBN 1/4P 220K
661	C581	5345-225F0962	CAP, MINI ELE 2.2U/50V	636	R422	5134-224J25P	RES, CBN 1/4P 220K
661	C582	5345-225F0962	CAP, MINI ELE 2.2U/50V	637	R423	5134-181J25P	RES, CBN 1/4P 180
669	C585	5354-273J1HM	CAP, MYL .027U	637	R424	5134-181J25P	RES, CBN 1/4P 180
669	C586	5354-273J1HM	CAP, MYL .027U	645	△ R425	5102-8205116	RES, FUSE 82
663	C587	5354-154593	CAP, MYL .15U	645	△ R426	5102-8205116	RES, FUSE 82
663	C588	5354-154593	CAP, MYL .15U	648	△ R427	5102-6805116	RES, FUSE 68
664	C589	5345-106C0962	CAP, MINI ELE 10U/16V	648	△ R428	5102-6805116	RES, FUSE 68
664	C590	5345-106C0962	CAP, MINI ELE 10U/16V	645	△ R429	5102-8205116	RES, FUSE 82
666	C591	5354-682J1HM	CAP, MYL 6800P	645	△ R430	5102-8205116	RES, FUSE 82
666	C592	5354-682J1HM	CAP, MYL 6800P	645	△ R431	5102-8205116	RES, FUSE 82
668	C593	5354-393J1HM	CAP, MYL .039U	645	△ R432	5102-8205116	RES, FUSE 82
668	C594	5354-393J1HM	CAP, MYL .039U	638	R433	5134-153J25P	RES, CBN 1/4P 15K
876	C801	5352-S110J104	CAP, MTL .1U	638	R434	5134-153J25P	RES, CBN 1/4P 15K
876	C802	5352-S110J104	CAP, MTL .1U	638	R435	5134-153J25P	RES, CBN 1/4P 15K
876	C803	5352-S110J104	CAP, MTL .1U	638	R436	5134-153J25P	RES, CBN 1/4P 15K
876	C804	5352-S110J104	CAP, MTL .1U	656	R437	5134-751J25P	RES, CBN 1/4P 750
879	C805	5352-S110J224	CAP, MTL .22U	656	R438	5134-751J25P	RES, CBN 1/4P 750
879	C807	5352-S110J224	CAP, MTL .22U	640	R439	5134-561J25P	RES, CBN 1/4P 560
879	C808	5352-S110J224	CAP, MTL .22U	640	R440	5134-561J25P	RES, CBN 1/4P 560
876	C809	5352-S110J104	CAP, MTL .1U	639	R441	5134-272J25P	RES, CBN 1/4P 2.7K
877	C831	5345-337F0962	CAP, MINI ELE 330U/50V	639	R442	5134-272J25P	RES, CBN 1/4P 2.7K
880	C832	5345-337D0962	CAP, MINI ELE 330U/25V	655	R443	5134-122J25P	RES, CBN 1/4P 1.2K
878	C833	5345-107D0962	CAP, MINI ELE 100U/25V	655	R444	5134-122J25P	RES, CBN 1/4P 1.2K
RESISTORS							
702	R27	5134-104J25P	RES, CBN 1/4P 100K	650	R445	5272-S010JR22	RES, CEM 2P .22
702	R28	5134-104J25P	RES, CBN 1/4P 100K	650	R446	5272-S010JR22	RES, CEM 2P .22
706	R30	5134-683J25P	RES, CBN 1/4P 68K	650	R447	5272-S010JR22	RES, CEM 2P .22
707	R34	5134-472J25P	RES, CBN 1/4P 4.7K	650	R448	5272-S010JR22	RES, CEM 2P .22
703	R35	5134-223J25P	RES, CBN 1/4P 22K	646	△ R449	5102-2215116	RES, FUSE 220
703	R36	5134-223J25P	RES, CBN 1/4P 22K	646	△ R450	5102-2215116	RES, FUSE 220
706	R38	5134-683J25P	RES, CBN 1/4P 68K	651	R451	5272-S010KR10	RES, CEM 2P .1
705	R39	5134-824J25P	RES, CBN 1/4P 820K	651	R452	5272-S010KR10	RES, CEM 2P .1
709	R45	5134-682J25P	RES, CBN 1/4P 6.8K	644	△ R453	5102-1014715	RES, FUSE 100
709	R46	5134-682J25P	RES, CBN 1/4P 6.8K	644	△ R454	5102-1014715	RES, FUSE 100
710	R47	5134-152J25P	RES, CBN 1/4P 1.5K	644	△ R455	5102-1014715	RES, FUSE 100
710	R48	5134-152J25P	RES, CBN 1/4P 1.5K	644	△ R456	5102-1014715	RES, FUSE 100
711	R49	5134-821J25P	RES, CBN 1/4P 820	652	R457	5173-3R3583	RES, MTL 2P 3.3
				652	R458	5173-3R3583	RES, MTL 2P 3.3
				641	R459	5134-332J25P	RES, CBN 1/4P 3.3K
				641	R460	5134-332J25P	RES, CBN 1/4P 3.3K
				649	△ R461	5102-4R75116	RES, FUSE 4.7
				649	△ R462	5102-4R75116	RES, FUSE 4.7
				649	△ R463	5102-4R75116	RES, FUSE 4.7

Ser. No.	Ref. No.	Part No.	Description	Ser. No.	Ref. No.	Part No.	Description
649	△ R464	5102-4R75116	RES, FUSE 4.7	698	Q20	5611-970(BL)	XISTOR, PNP R
642	R465	5134-331J25P	RES, CBN 1/4P 330	697	Q91	5611-933(S)	XISTOR, PNP R
642	R466	5134-331J25P	RES, CBN 1/4P 330	613	Q401	5613-1775(F)	XISTOR, NPN R
647	△ R475	5102-3914715	RES, FUSE 390	613	Q402	5613-1775(F)	XISTOR, NPN R
647	△ R476	5102-3914715	RES, FUSE 390	613	Q403	5613-1775(F)	XISTOR, NPN R
642	R493	5134-331J25P	RES, CBN 1/4P 330	613	Q404	5613-1775(F)	XISTOR, NPN R
642	R494	5134-331J25P	RES, CBN 1/4P 330	614	Q405	5612-646A(C)	XISTOR, PNP A
633	R497	5134-473J25P	RES, CBN 1/4P 47K	614	Q406	5612-646A(C)	XISTOR, PNP A
633	R498	5134-473J25P	RES, CBN 1/4P 47K	614	Q407	5612-646A(C)	XISTOR, PNP A
671	R503	5134-102J25P	RES, CBN 1/4P 1K	614	Q408	5612-646A(C)	XISTOR, PNP A
671	R504	5134-102J25P	RES, CBN 1/4P 1K	615	Q409	5613-2240(BL)	XISTOR, NPN R
672	R581	5134-153J25P	RES, CBN 1/4P 15K	615	Q410	5613-2240(BL)	XISTOR, NPN R
672	R582	5134-153J25P	RES, CBN 1/4P 15K	615	Q411	5613-2240(BL)	XISTOR, NPN R
673	R583	5134-272J25P	RES, CBN 1/4P 2.7K	615	Q412	5613-2240(BL)	XISTOR, NPN R
673	R584	5134-272J25P	RES, CBN 1/4P 2.7K	614	Q413	5612-646A(C)	XISTOR, PNP A
674	R587	5134-331J25P	RES, CBN 1/4P 330	614	Q414	5612-646A(C)	XISTOR, PNP A
674	R588	5134-331J25P	RES, CBN 1/4P 330	616	Q415	5614-666A(C)	XISTOR, NPN A
676	R591	5134-122J25P	RES, CBN 1/4P 1.2K	616	Q416	5614-666A(C)	XISTOR, NPN A
676	R592	5134-122J25P	RES, CBN 1/4P 1.2K	617	Q417	5613-3423(Y)	XISTOR, NPN R
677	R593	5134-121J25P	RES, CBN 1/4P 120	617	Q418	5613-3423(Y)	XISTOR, NPN R
677	R594	5134-121J25P	RES, CBN 1/4P 120	618	Q419	5614-667A(C)	XISTOR, NPN A
678	R595	5232-104J16P	RES, CBN 1/6P 100K	618	Q420	5614-667A(C)	XISTOR, NPN A
678	R596	5232-104J16P	RES, CBN 1/6P 100K	619	Q421	5612-647A(C)	XISTOR, PNP A
896	R801	5134-102J25P	RES, CBN 1/4P 1K	619	Q422	5612-647A(C)	XISTOR, PNP A
896	R802	5134-102J25P	RES, CBN 1/4P 1K	620	Q423	5611-1837(Y)	XISTOR, PNP R
896	R803	5134-102J25P	RES, CBN 1/4P 1K	620	Q424	5611-1837(Y)	XISTOR, PNP R
896	R804	5134-102J25P	RES, CBN 1/4P 1K	621	Q425	5613-4793(Y)	XISTOR, NPN R
896	R805	5134-102J25P	RES, CBN 1/4P 1K	621	Q426	5613-4793(Y)	XISTOR, NPN R
896	R806	5134-102J25P	RES, CBN 1/4P 1K	623	Q427	5613-3181(O)	XISTOR, NPN R
896	R807	5134-102J25P	RES, CBN 1/4P 1K	623	Q428	5613-3181(O)	XISTOR, NPN R
896	R808	5134-102J25P	RES, CBN 1/4P 1K	624	Q429	5611-1264(O)	XISTOR, PNP R
896	R811	5134-102J25P	RES, CBN 1/4P 1K	624	Q430	5611-1264(O)	XISTOR, PNP R
896	R812	5134-102J25P	RES, CBN 1/4P 1K	612	Q431	5613-1775(F)	XISTOR, NPN R
896	R813	5134-102J25P	RES, CBN 1/4P 1K	612	Q432	5613-1775(F)	XISTOR, NPN R
897	R814	5134-102J25P	RES, CBN 1/4P 1K	611	Q433	5614-666A(C)	XISTOR, NPN A
897	R815	5134-102J25P	RES, CBN 1/4P 1K	611	Q434	5614-666A(C)	XISTOR, NPN A
897	R816	5134-102J25P	RES, CBN 1/4P 1K	887	Q801	5616-2SK364BL	FET, N-CH
897	R817	5134-102J25P	RES, CBN 1/4P 1K	887	Q802	5616-2SK364BL	FET, N-CH
897	R818	5134-102J25P	RES, CBN 1/4P 1K	887	Q803	5616-2SK364BL	FET, N-CH
894	R819	5134-225J25P	RES, CBN 1/4P 2.2M	887	Q804	5616-2SK364BL	FET, N-CH
894	R820	5134-225J25P	RES, CBN 1/4P 2.2M	887	Q805	5616-2SK364BL	FET, N-CH
894	R821	5134-225J25P	RES, CBN 1/4P 2.2M	887	Q806	5616-2SK364BL	FET, N-CH
894	R822	5134-225J25P	RES, CBN 1/4P 2.2M	887	Q807	5616-2SK364BL	FET, N-CH
898	R824	5134-105J25P	RES, CBN 1/4P 1M	887	Q808	5616-2SK364BL	FET, N-CH
899	R825	5134-155J25P	RES, CBN 1/4P 1.5M	887	Q811	5616-2SK364BL	FET, N-CH
899	R826	5134-155J25P	RES, CBN 1/4P 1.5M	887	Q812	5616-2SK364BL	FET, N-CH
894	R827	5134-225J25P	RES, CBN 1/4P 2.2M	889	Q813	5616-2SK364BL	FET, N-CH
900	R829	5134-104J25P	RES, CBN 1/4P 100K	889	Q814	5616-2SK364BL	FET, N-CH
900	R830	5134-104J25P	RES, CBN 1/4P 100K	887	Q815	5616-2SK364BL	FET, N-CH
900	R831	5134-104J25P	RES, CBN 1/4P 100K	888	Q816	5616-2SK364BL	FET, N-CH
900	R832	5134-104J25P	RES, CBN 1/4P 100K	888	Q817	5616-2SK364BL	FET, N-CH
900	R834	5134-104J25P	RES, CBN 1/4P 100K	888	Q818	5616-2SK364BL	FET, N-CH
900	R835	5134-104J25P	RES, CBN 1/4P 100K	891	Q828	5613-C144ES	XISTOR, NPN R
900	R836	5134-104J25P	RES, CBN 1/4P 100K	891	Q829	5613-C144ES	XISTOR, NPN R
900	R839	5134-104J25P	RES, CBN 1/4P 100K	885	Q831	5613-2320L(F)	XISTOR, NPN R
895	R841	5232-225J16P	RES, CBN 1/6P 2.2M				
895	R842	5232-225J16P	RES, CBN 1/6P 2.2M				
895	R843	5232-225J16P	RES, CBN 1/6P 2.2M				
895	R844	5232-225J16P	RES, CBN 1/6P 2.2M				
895	R845	5232-225J16P	RES, CBN 1/6P 2.2M				
895	R846	5232-225J16P	RES, CBN 1/6P 2.2M				
895	R847	5232-225J16P	RES, CBN 1/6P 2.2M				
895	R848	5232-225J16P	RES, CBN 1/6P 2.2M				
895	R849	5232-225J16P	RES, CBN 1/6P 2.2M				
895	R850	5232-225J16P	RES, CBN 1/6P 2.2M				
903	△ R851	5102-2205116	RES, FUSE 22				
905	R852	5134-272J25P	RES, CBN 1/4P 2.7K				
904	R853	5134-562J25P	RES, CBN 1/4P 5.6K				
906	R854	5134-222J25P	RES, CBN 1/4P 2.2K				
		TRANSISTORS				DIODES	
699	Q15	5613-1740(S)	XISTOR, NPN R	725	△ D19	5685-D5SB20	SILICON, BRIG
697	Q16	5611-933(S)	XISTOR, PNP R	695	D25	5631-1S2473	DIODE, DET
699	Q17	5613-1740(S)	XISTOR, NPN R	695	D26	5631-1S2473	DIODE, DET
698	Q19	5611-970(BL)	XISTOR, PNP R	717	D91	5632-S5566B	DIODE, RECT
				718	D93	5635-HZ6B1L	DIODE, ZENER
				882	D801	5631-1S2473	DIODE, DET
				882	D802	5631-1S2473	DIODE, DET
				882	D803	5631-1S2473	DIODE, DET
				882	D804	5631-1S2473	DIODE, DET
				882	D805	5631-1S2473	DIODE, DET
				882	D806	5631-1S2473	DIODE, DET
				882	D807	5631-1S2473	DIODE, DET
				882	D808	5631-1S2473	DIODE, DET
				882	D811	5631-1S2473	DIODE, DET
				882	D812	5631-1S2473	DIODE, DET
				882	D813	5631-1S2473	DIODE, DET
				883	D814	5631-1S2473	DIODE, DET
				883	D815	5631-1S2473	DIODE, DET

Ser. No.	Ref. No.	Part No.	Description
883	D816	5631-1S2473	DIODE, DET
883	D817	5631-1S2473	DIODE, DET
883	D818	5631-1S2473	DIODE, DET
881	D819	5631-1S2473	DIODE, DET
881	D820	5631-1S2473	DIODE, DET
884	D831	5635-HZ18-2L	DIODE, ZENER
884	D832	5635-HZ18-2L	DIODE, ZENER

CONTROLS

654	VR401	5101-30101934	RES, SEMI FIX 300, IDLING CURRENT
654	VR402	5101-30101934	RES, SEMI FIX 300, IDLING CURRENT
824	VR501/502	5113-S2005104	RES, V CBN 16 100K, BALANCE
822	VR505/506	5113-50342122	RES, V CBN 16 50K, TREBLE
820	VR507/508	5113-10441122	RES, V CBN 16 100K, BASS

MISCELLANEOUS

806	CN91	4443-0201140	CONNECTOR, 2 PIN
805	CN101	4443-030185	CONNECTOR, 3 PIN
784	CN102	4443-0201140	CONNECTOR, 2 PIN
795	CW5	4163-0130025	CONNECTOR W/W, 1 PIN
793	CW6	4163-0130024	CONNECTOR W/W, 1 PIN
794	CW7	4163-0130026	CONNECTOR W/W, 1 PIN
813	J1	4489-04303008	PIN JACK, MLT, CD/TUNER/VIDEO/AUX
813	J2	4489-04303008	PIN JACK, MLT, TAPE 1/TAPE 2 IN/OUT
800	JL101	4242-R0503101	JUMPER LEAD, 3 WIRE
786	JL431	4132-R0202101	CORD, 2C
800	JL501	4242-R0503101	JUMPER LEAD, 3 WIRE
630	L401	5597-45502	CORE, BEADS
630	L402	5597-45502	CORE, BEADS
630	L403	5597-45502	CORE, BEADS
630	L404	5597-45502	CORE, BEADS
763	LCN401	4163-0140025	CONNECTOR W/W, 1 PIN
764	LCN402	4163-0140027	CONNECTOR W/W, 1 PIN
761	LCN403	4163-0140024	CONNECTOR W/W, 1 PIN
762	LCN404	4163-0140026	CONNECTOR W/W, 1 PIN
792	LCN411	4163-0117024	CONNECTOR W/W, 1 PIN
783	TM101	4214-262	TERMINAL
783	TM102	4214-262	TERMINAL
783	TM103	4214-262	TERMINAL
783	TM104	4214-262	TERMINAL
783	TM105	4214-262	TERMINAL
785	TP401	4214-262	TERMINAL
785	TP402	4214-262	TERMINAL
785	TP403	4214-262	TERMINAL
785	TP404	4214-262	TERMINAL
787	W401	4162-01201700	LUG W/WIRE
770	W402	4122-00280121	WIRE
770	W403	4122-00280121	WIRE
796	W410	4122-00280401	WIRE
799	W502	4142-00151301	SHLD WIRE, 2C
780		2240-Z032	HOLDER, H501(JL501), H101(JL101)
781		2240-Z031	HOLDER, H504(W-502)

PCB-2 FUNCTION P.C. BOARD

MISCELLANEOUS

901	SW501	4411-00601203	SWITCH, ROTARY, SOURCE
902	SW502	4411-00602202	SWITCH, ROTARY, TAPE

PCB-3 SP SW P.C. BOARD

CAPACITORS

758	C81	5361-101KB	CAP, CER 100P
758	C82	5361-101KB	CAP, CER 100P

Ser. No.	Ref. No.	Part No.	Description
RESISTORS			
760	R81	5134-471J25P	RES, CBN 1/4P 470
760	R82	5134-471J25P	RES, CBN 1/4P 470

MISCELLANEOUS

829	HP401	4451-00158	JACK, 1P, HEADPHONES
765	LCN405	4163-0140025	CONNECTOR W/W, 1 PIN
767	LCN406	4163-0140024	CONNECTOR W/W, 1 PIN
766	LCN407	4163-0140027	CONNECTOR W/W, 1 PIN
768	LCN408	4163-0140026	CONNECTOR W/W, 1 PIN
817	SW401	4431-S0319204	SWITCH, PUSH, SPEAKERS 1/2

PCB-4 SECOND P.C. BOARD

CAPACITORS

721	C2	5354-104593	CAP, MYL .1U
721	C3	5354-104593	CAP, MYL .1U

PCB-5 SP TERMINAL P.C. BOARD

CAPACITORS

657	C83	5361-151KB	CAP, CER 150P
657	C84	5361-151KB	CAP, CER 150P
657	C85	5361-151KB	CAP, CER 150P
657	C86	5361-151KB	CAP, CER 150P

MISCELLANEOUS

812	TM402	4214-239	TERMINAL, SPEAKER SYSTEM 1/2
-----	-------	----------	------------------------------

PCB-6 PR P.C. BOARD

MISCELLANEOUS

810	△ CN1	4443-09501002	CONNECTOR, 2 PIN
727	△ F1	5732-01601122	FUSE, T1.25A/T1.25AL 250V
728	△ HF1	4472-04901	HOLDER, FUSE, F1
728	△ HF2	4472-04901	HOLDER, FUSE, F1
788	△ LCN101	4163-S5101300	CONNECTOR W/W, 1 PIN
789	△ LCN102	4163-S5201300	CONNECTOR W/W, 1 PIN

PCB-7 POWER SW P.C. BOARD

CAPACITOR

730	△ C1	5352-1030958	CAP, MTL .01U
-----	------	--------------	---------------

RESISTOR

732	△ R1	5134-335J25P	RES, CBN 1/4P 3.3M
-----	------	--------------	--------------------

MISCELLANEOUS

731	△ SW1	4433-00401	SWITCH, PU-PW, POWER
-----	-------	------------	----------------------

PCB-8 POWER IND P.C. BOARD

CAPACITOR

838	C93	5345-106C0962	CAP, MINI ELE 10U/16V
-----	-----	---------------	-----------------------

DIODES

839	D94	5637-S2410E1A	LED, POWER
839	D95	5637-S2410E1A	LED, POWER

MISCELLANEOUS

798	CW91	4163-S5302351	CONNECTOR W/W, 2 PIN
-----	------	---------------	----------------------

Ser. No. Ref. No. Part No. Description

PCB & VR P.C. BOARD

RESISTORS			
830	R501	5134-152J25P	RES, CBN 1/4P 1.5K
830	R502	5134-152J25P	RES, CBN 1/4P 1.5K
CONTROLS			
826	VR503/504	5113-S2004303	RES, V CBN 16 30K, VOLUME
MISCELLANEOUS			
779		2240-Z031	HOLDER, H503(W-502)
782		2240-Z032	HOLDER, H502(JL501)

CHASSIS MISCELLANEOUS

MISCELLANEOUS			
811	△ PG1	4161-10201202	CORD W/PLUG
723	△ PT1	5584-T4401	XFORMER, POWER

PACKING PARTS LIST

108		1111-1610M152	OWNER GUIDE
116		1756-03108	LABEL, (I) LABEL, CARTON BOX (*2)
120		1241-R0160601	POLYETHY BAG, SET
121		1241-R0123351	POLYETHY BAG
124		1221-34009	CARTON BOX
126		1222-7413	CUSHION (L)
127		1222-7414	CUSHION (R)
128		1223-R0420055	SOFT SHEET, SET
021A		1756-23601	LABEL, (CH) LABEL, CARTON

ABBREVIATIONS IN PARTS LIST

CAPACITORS

CAP, MINI ELE	: Electrolytic
CAP, CER	: Ceramic
CAP, PPP	: Polypropylene
CAP, MYL	: Mylar
CAP, MCA	: Mica
CAP, MINI BP	: Bipolar
CAP, ELE BP	: Electrolytic Bipolar
470U	: 470µF
6800P	: 6800pF
.047U	: 0.047µF

RESISTORS

RES, CBN 1/6P	: Carbon 1/6W
RES, FUSE	: Fuse
RES, CEM 5P	: Cement 5W
RES, MTL 1P	: Metal 1W
2.2k	: 2.2kΩ
220	: 220Ω

TRANSISTORS

XISTOR	: Transistor
FET	: Field Effect Transistor

CONTROLS

RES, V CBN	: Variable Carbon Resistor
RES, SEMI FIX	: Semi-fixed Resistor

NOTE



SAFETY RELATED COMPONENT. USE ONLY EXACT REPLACEMENT PART AS SPECIFIED.

WIRING DIAGRAM

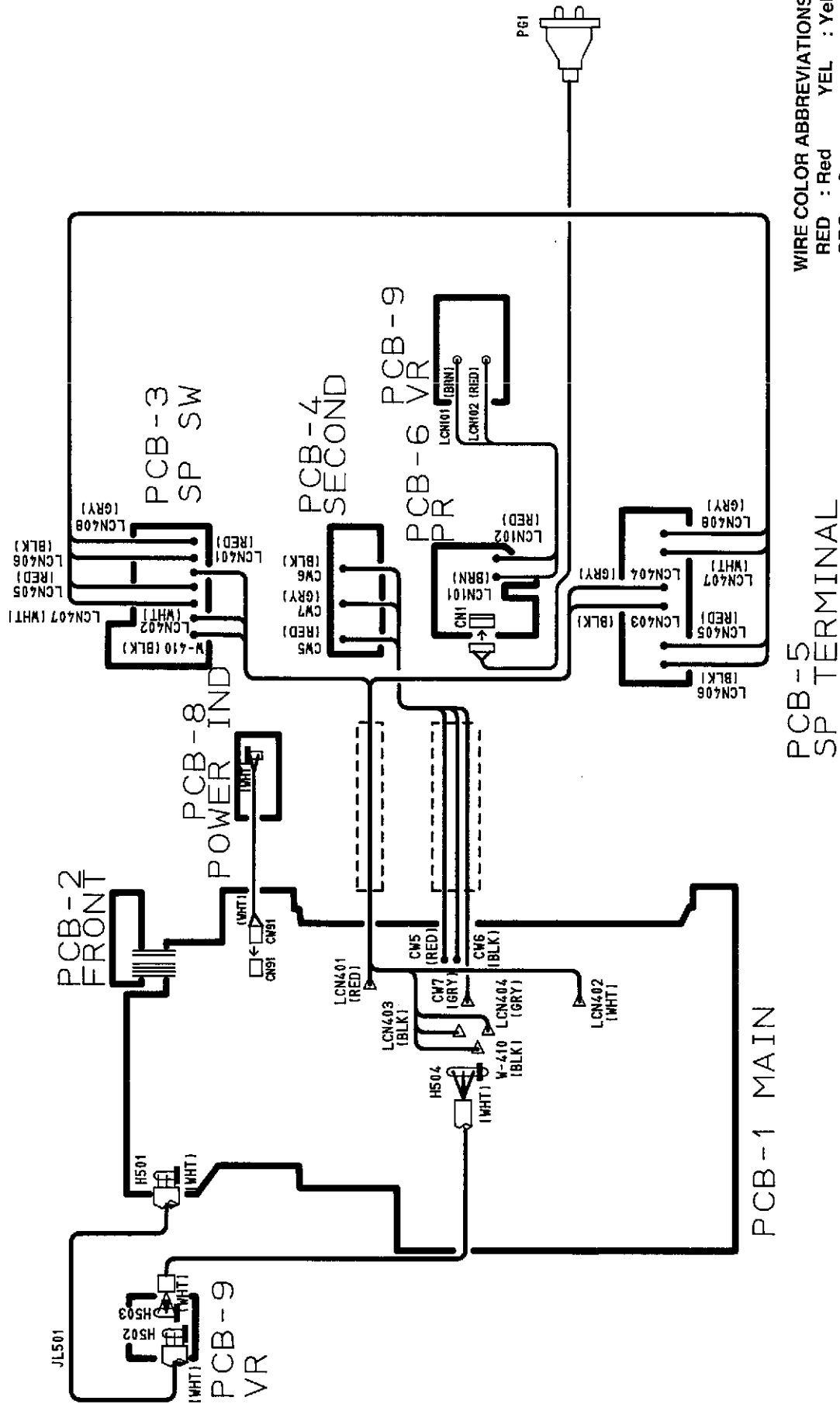

WIRE COLOR ABBREVIATIONS
 RED : Red
 YEL : Yellow
 ORG : Orange
 PUP : Purple
 BLU : Blue
 PIK : Pink
 WHT : White
 GRY : Gray
 GRN : Green
 BRN : Brown
 BLK : Black

1
2
3
4
5
6
7

A B C D E

PH600 Phono PCB Option:

When this option is installed, MM or MC turntables can be connected to the RCA jacks on the Phono PCB. To use the Phono input, the function selector switch on the front panel must be set to the AUX position. Please note that which the Phono PCB option installed, signal wires shall not be connected to the AUX RCA connectors. Signal applied to the AUX input with the Phono option installed, will be attenuated and may be distorted. Installation of Optional Phono PCB (PH600):

(Please re-print the information from information sheet you already prepared.)

HOW TO INSTALL

- ① Remove 6 screws and then remove the Top Cover.
- ② Remove a screw and a rivet and then remove the plate.

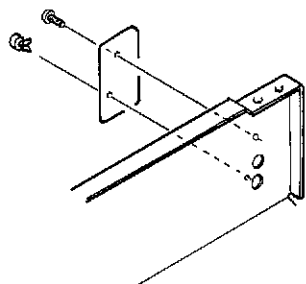

- ④ Secure the screw removed from the plate and the ground terminal screw (included).

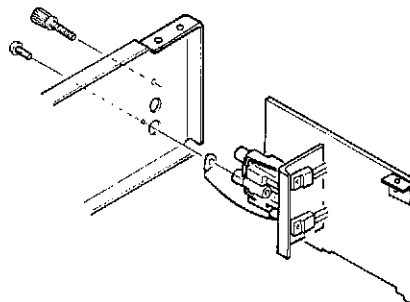

- ③ Insert PH600 into two slots of the bottom.

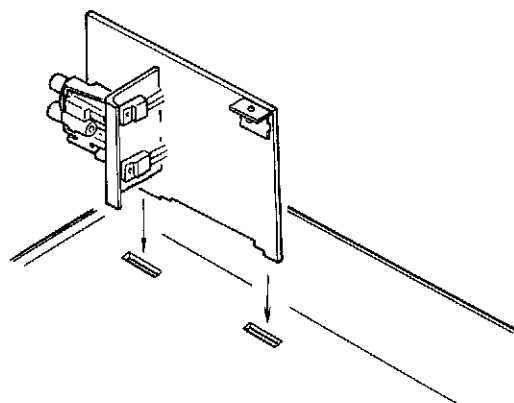

- ⑤ Connect the 2 cables precisely as shown in the illustration.

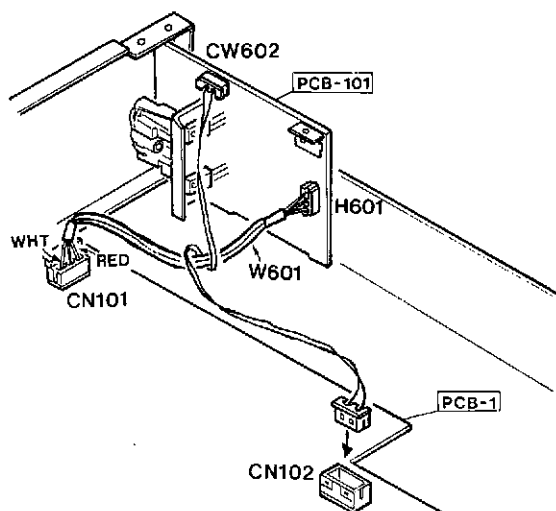

GENERAL UNIT

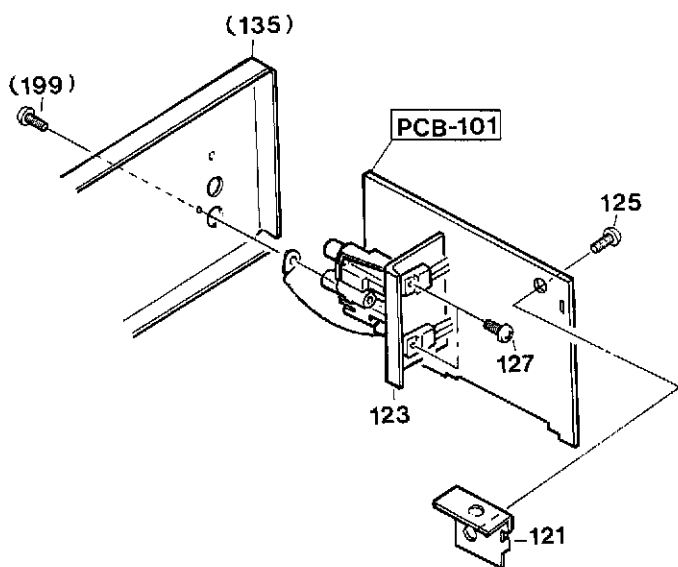

GENERAL UNIT PARTS LIST

Ser. No	Ref. No.	Part No.	Description
121		2219-8350	METAL FITTIG
123		2222-7179	HEAT SINK
125		2347-R0130062	SCREW, BND T+ (3×6 mm)
127		2347-R0130082	SCREW, BND T+ (3×8 mm) (×2)

P.C. BOARD

The PH600 is set at the factory as a high gain MC EQ amplifier. It can easily be converted to a MM EQ amplifier by making these changes:

1. Remove L701 and L702 (bare wires with ferrite beads),
2. Remove C701 and C702 (0.022μF capacitors, marked 223J),
3. Remove R715 and R716 (1kΩ resistors), and
4. Add 2 jumper wires (JP) along the dotted lines on the circuit board (near the location of R715 and R716).

PCB-101 MC VERSION (Factory setting)

PCB-101 MM VERSION

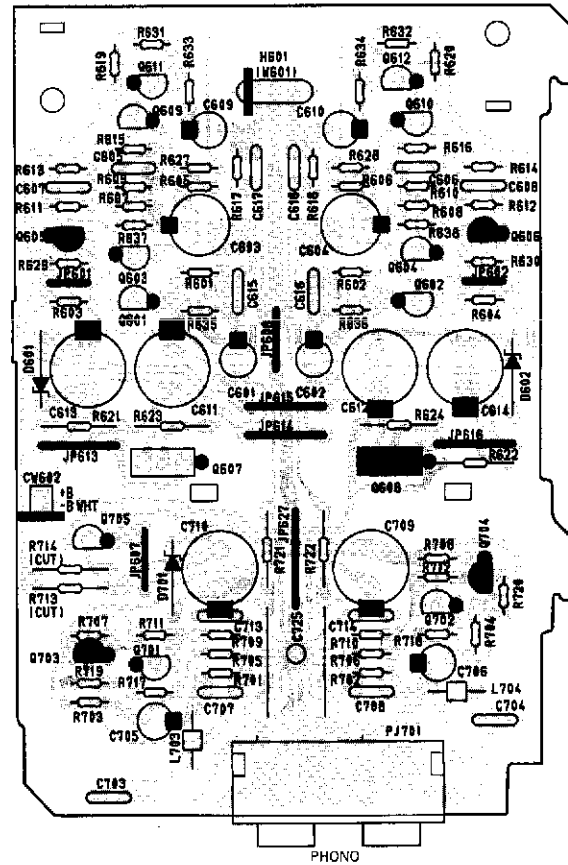
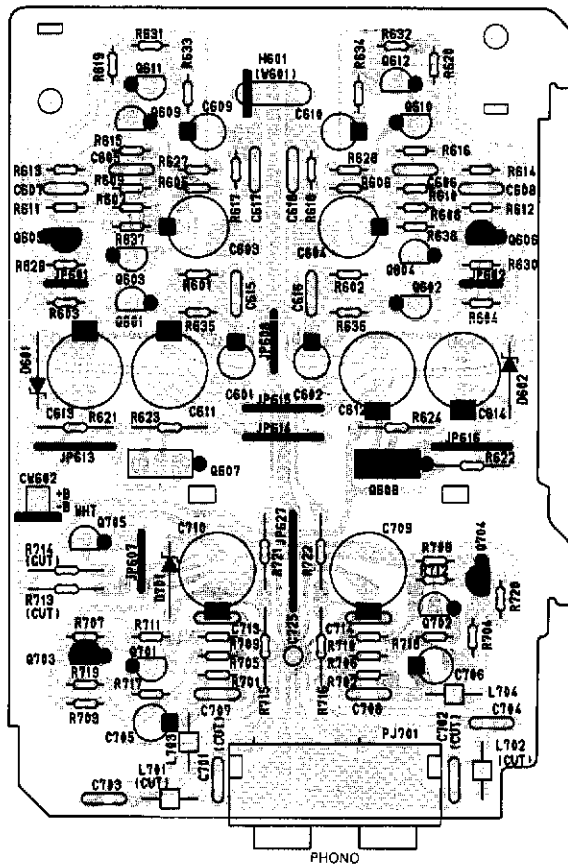

L701, L702 → Delete

C701, C702 → Delete

R715, R716 → Delete

Add 2 jumper wires (JP) along dotted lines

WIRING DIAGRAM

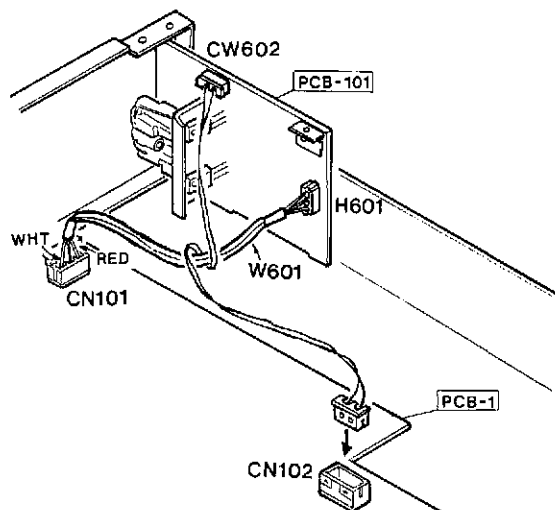

SCHEMATIC DIAGRAM

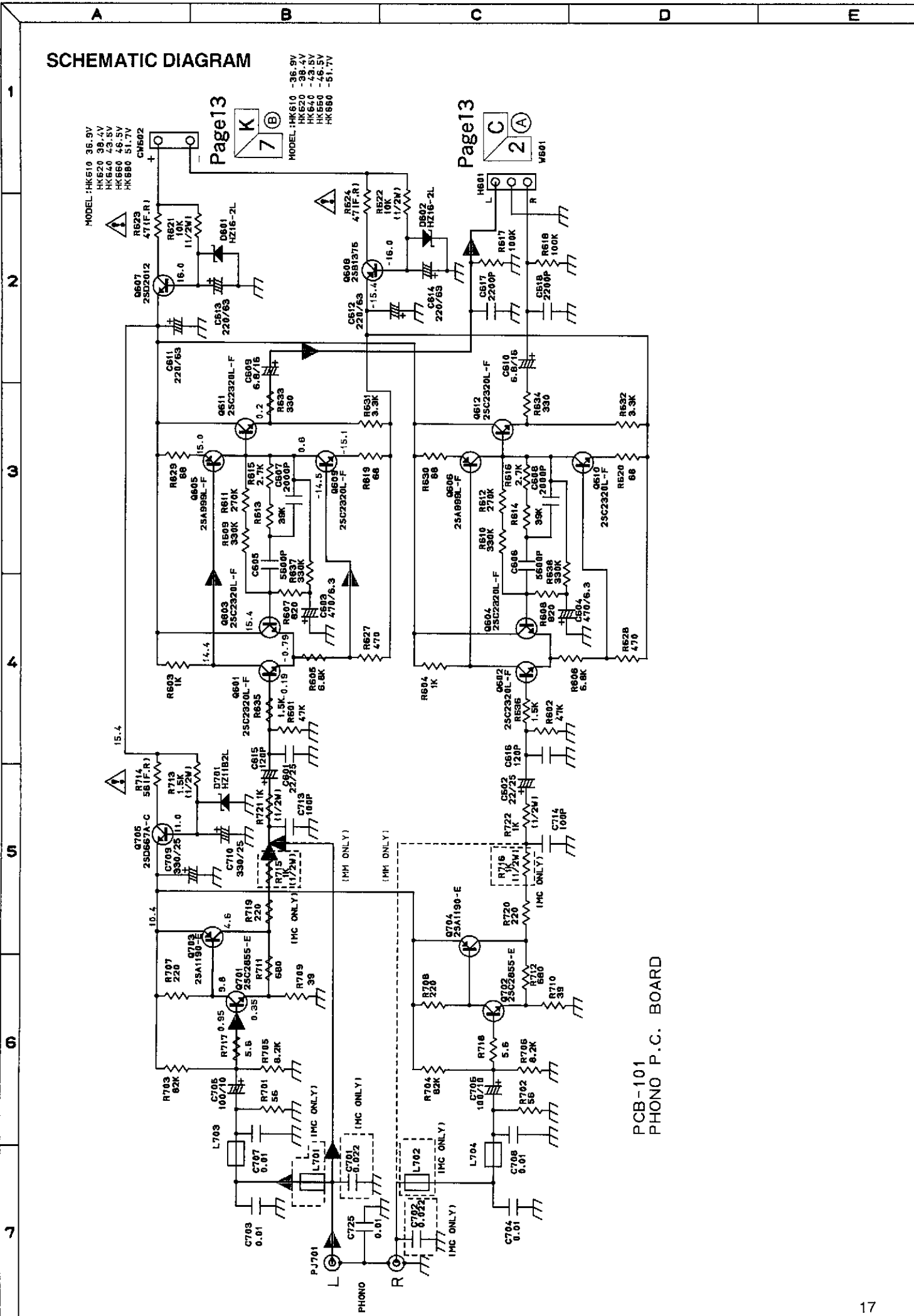

PCB-101
PHONO P.C. BOARD

ELECTRICAL PARTS LIST

Ser. No.	Ref. No.	Part No.	Description	Ser. No.	Ref. No.	Part No.	Description
PCB-101 PHONO P.C. BOARD							
CAPACITORS							
400	C601	5345-S29DM226	CAP, MINI ELE 22U/25V	417	R638	5178-334381	RES, MTL 1/6P 330K
400	C602	5345-S29DM226	CAP, MINI ELE 22U/25V	450	R701	5130-R010J560	RES, CBN 1/6P 56
401	C603	5345-S29AD477	CAP, MINI ELE 470U/6.3V	450	R702	5130-R010J560	RES, CBN 1/6P 56
401	C604	5345-S29AD477	CAP, MINI ELE 470U/6.3V	456	R703	5130-R010J823	RES, CBN 1/6P 82K
402	C605	5359-5625851	CAP, PPP 5600P	456	R704	5130-R010J823	RES, CBN 1/6P 82K
402	C606	5359-5625851	CAP, PPP 5600P	451	R705	5130-R010J822	RES, CBN 1/6P 8.2K
403	C607	5359-2025851	CAP, PPP 2000P	451	R706	5130-R010J822	RES, CBN 1/6P 8.2K
403	C608	5359-2025851	CAP, PPP 2000P	458	R707	5130-R010J221	RES, CBN 1/6P 220
404	C609	5345-685C0951	CAP, MINI ELE 6.8U/16V	458	R708	5130-R010J221	RES, CBN 1/6P 220
404	C610	5345-685C0951	CAP, MINI ELE 6.8U/16V	452	R709	5178-390381	RES, MTL 1/6P 39
405	C611	5345-S25GM227	CAP, MINI ELE 220U/63V	452	R710	5178-390381	RES, MTL 1/6P 39
405	C612	5345-S25GM227	CAP, MINI ELE 220U/63V	453	R711	5178-681381	RES, MTL 1/6P 680
405	C613	5345-S25GM227	CAP, MINI ELE 220U/63V	453	R712	5178-681381	RES, MTL 1/6P 680
405	C614	5345-S25GM227	CAP, MINI ELE 220U/63V	454	R713	5130-R030J152	RES, CBN 1/2P 1.5K
406	C615	5359-1215851	CAP, PPP 120P	457	R714	5102-5604713	RES, FUSE 56
406	C616	5359-1215851	CAP, PPP 120P	459	R715	5130-R030J102	RES, CBN 1/2P 1K
430	C617	5359-2225851	CAP, PPP 2200P	459	R716	5130-R030J102	RES, CBN 1/2P 1K
430	C618	5359-2225851	CAP, PPP 2200P	440	R717	5130-R010J5R6	RES, CBN 1/6P 5.6
441	C701	5359-S010J223	CAP, PPP .022U	440	R718	5130-R010J5R6	RES, CBN 1/6P 5.6
441	C702	5359-S010J223	CAP, PPP .022U	458	R719	5130-R010J221	RES, CBN 1/6P 220
442	C703	5359-S010J103	CAP, PPP .01U	458	R720	5130-R010J221	RES, CBN 1/6P 220
442	C704	5359-S010J103	CAP, PPP .01U	459	R721	5130-R030J102	RES, CBN 1/2P 1K
443	C705	5345-S29BM107	CAP, MINI ELE 100U/10V	459	R722	5130-R030J102	RES, CBN 1/2P 1K
443	C706	5345-S29BM107	CAP, MINI ELE 100U/10V	TRANSISTORS			
442	C707	5359-S010J103	CAP, PPP .01U	409	Q601	5613-2320L(F)	XISTOR, NPN R
442	C708	5359-S010J103	CAP, PPP .01U	409	Q602	5613-2320L(F)	XISTOR, NPN R
444	C709	5345-S25DM337	CAP, MINI ELE 330U/25V	409	Q603	5613-2320L(F)	XISTOR, NPN R
444	C710	5345-S25DM337	CAP, MINI ELE 330U/25V	409	Q604	5613-2320L(F)	XISTOR, NPN R
438	C713	5359-S010K101	CAP, PPP 100P	410	Q605	5611-999L(F)	XISTOR, PNP R
438	C714	5359-S010K101	CAP, PPP 100P	410	Q606	5611-999L(F)	XISTOR, PNP R
439	C725	5359-S010J103	CAP, PPP .01U	411	Q607	5614-2012	XISTOR, NPN A
RESISTORS							
413	R601	5130-R010J473	RES, CBN 1/6P 47K	412	Q608	5612-1375	XISTOR, PNP A
413	R602	5130-R010J473	RES, CBN 1/6P 47K	426	Q609	5613-2320L(F)	XISTOR, NPN R
414	R603	5130-R010J102	RES, CBN 1/6P 1K	426	Q610	5613-2320L(F)	XISTOR, NPN R
414	R604	5130-R010J102	RES, CBN 1/6P 1K	426	Q611	5613-2320L(F)	XISTOR, NPN R
415	R605	5130-R010J682	RES, CBN 1/6P 6.8K	426	Q612	5613-2320L(F)	XISTOR, NPN R
415	R606	5130-R010J682	RES, CBN 1/6P 6.8K	447	Q701	5613-2855(E)	XISTOR, NPN R
416	R607	5178-821381	RES, MTL 1/6P 820	447	Q702	5613-2855(E)	XISTOR, NPN R
416	R608	5178-821381	RES, MTL 1/6P 820	448	Q703	5611-1190(E)	XISTOR, PNP R
417	R609	5178-334381	RES, MTL 1/6P 330K	448	Q704	5611-1190(E)	XISTOR, PNP R
417	R610	5178-334381	RES, MTL 1/6P 330K	449	Q705	5614-667A(C)	XISTOR, NPN A
418	R611	5178-274381	RES, MTL 1/6P 270K	DIODES			
418	R612	5178-274381	RES, MTL 1/6P 270K	408	D601	5635-HZ16-2L	DIODE, ZENER
419	R613	5178-393381	RES, MTL 1/6P 39K	408	D602	5635-HZ16-2L	DIODE, ZENER
419	R614	5178-393381	RES, MTL 1/6P 39K	445	D701	5635-HZ11B2L	DIODE, ZENER
420	R615	5178-272381	RES, MTL 1/6P 2.7K	MISCELLANEOUS			
420	R616	5178-272381	RES, MTL 1/6P 2.7K	407	CW602	4163-S0202201	CONNECTOR W/W, 2 PIN
421	R617	5130-R010J104	RES, CBN 1/6P 100K	446	PJ701	4489-04006002	PIN JACK, MLT, PHONO
421	R618	5130-R010J104	RES, CBN 1/6P 100K	455	L701	5597-3	CORE, BEADS
428	R619	5130-R010J680	RES, CBN 1/6P 68	455	L702	5597-3	CORE, BEADS
428	R620	5130-R010J680	RES, CBN 1/6P 68	455	L703	5597-3	CORE, BEADS
422	R621	5130-R030J103	RES, CBN 1/2P 10K	455	L704	5597-3	CORE, BEADS
422	R622	5130-R030J103	RES, CBN 1/2P 10K	431	W601	4142-00151241	SHLD WIRE, 2C
423	R623	5102-4705116	RES, FUSE 47	437		4211-4	LUG, C725
423	R624	5102-4705116	RES, FUSE 47	432		2240-Z031	HOLDER, H601(W601)
429	R627	5130-R010J471	RES, CBN 1/6P 470	CHASSIS MISCELLANEOUS			
429	R628	5130-R010J471	RES, CBN 1/6P 470	MISCELLANEOUS			
428	R629	5130-R010J680	RES, CBN 1/6P 68	460		4214-168	TERMINAL, GND
428	R630	5130-R010J680	RES, CBN 1/6P 68	PACKING UNIT PARTS LIST			
427	R631	5130-R010J332	RES, CBN 1/6P 3.3K	MISCELLANEOUS			
427	R632	5130-R010J332	RES, CBN 1/6P 3.3K	107		1111-1780J152	OWNER GUIDE
424	R633	5130-R010J331	RES, CBN 1/6P 330	109		1231-00401	GIFT BOX
424	R634	5130-R010J331	RES, CBN 1/6P 330	113		1241-00501	POLYETHY BAG, SET
433	R635	5130-R010J152	RES, CBN 1/6P 1.5K	115		1756-00307	LABEL, OPTIONAL PHONO BOARD
433	R636	5130-R010J152	RES, CBN 1/6P 1.5K				
417	R637	5178-334381	RES, MTL 1/6P 330K				

A B C D E F G

SCHEMATIC DIAGRAM

Page 17

PCB-9
VR P.C. BOARD

PCB-1
MAIN P.C. BOARD

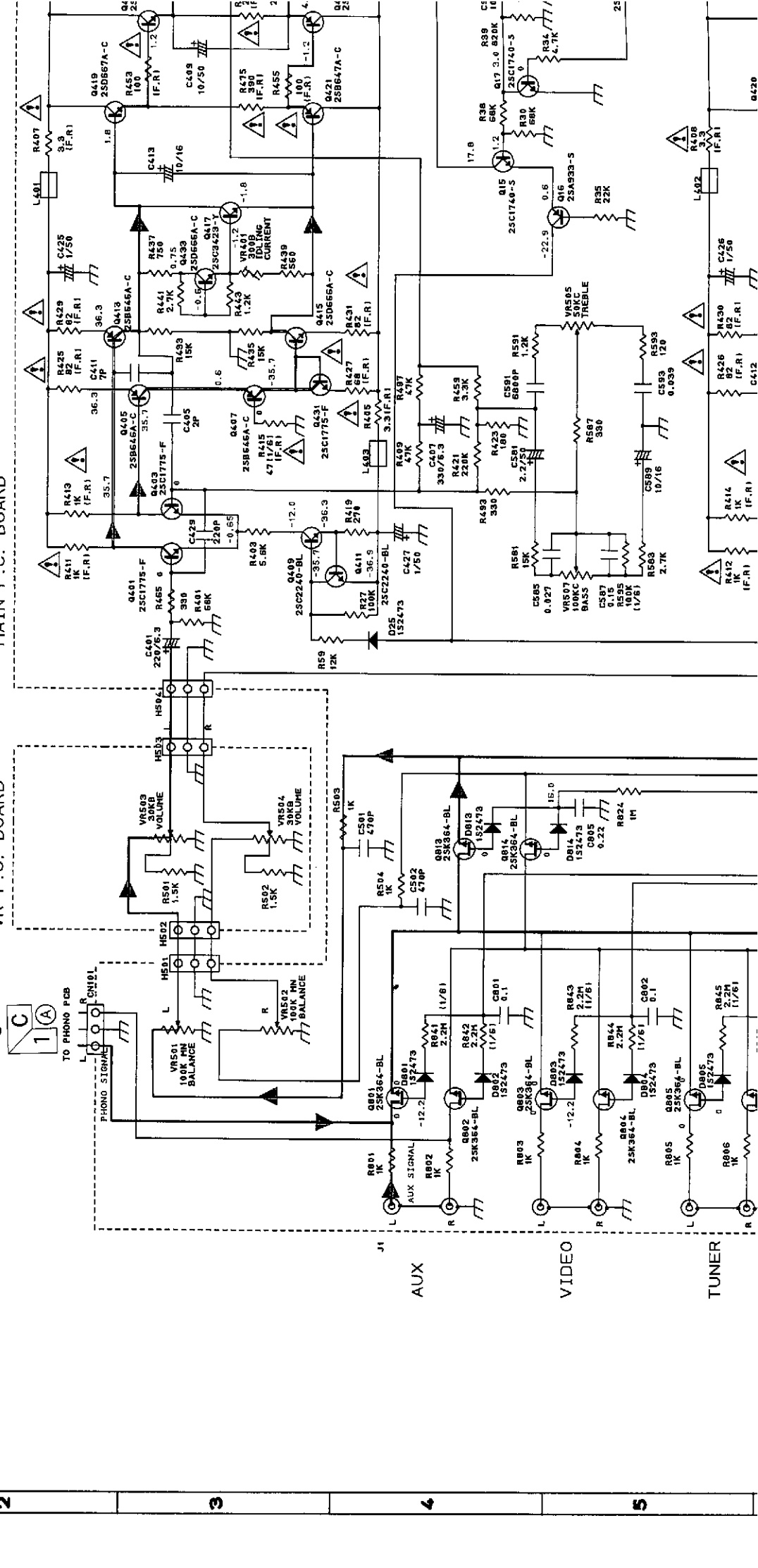

1

2

3

4

5

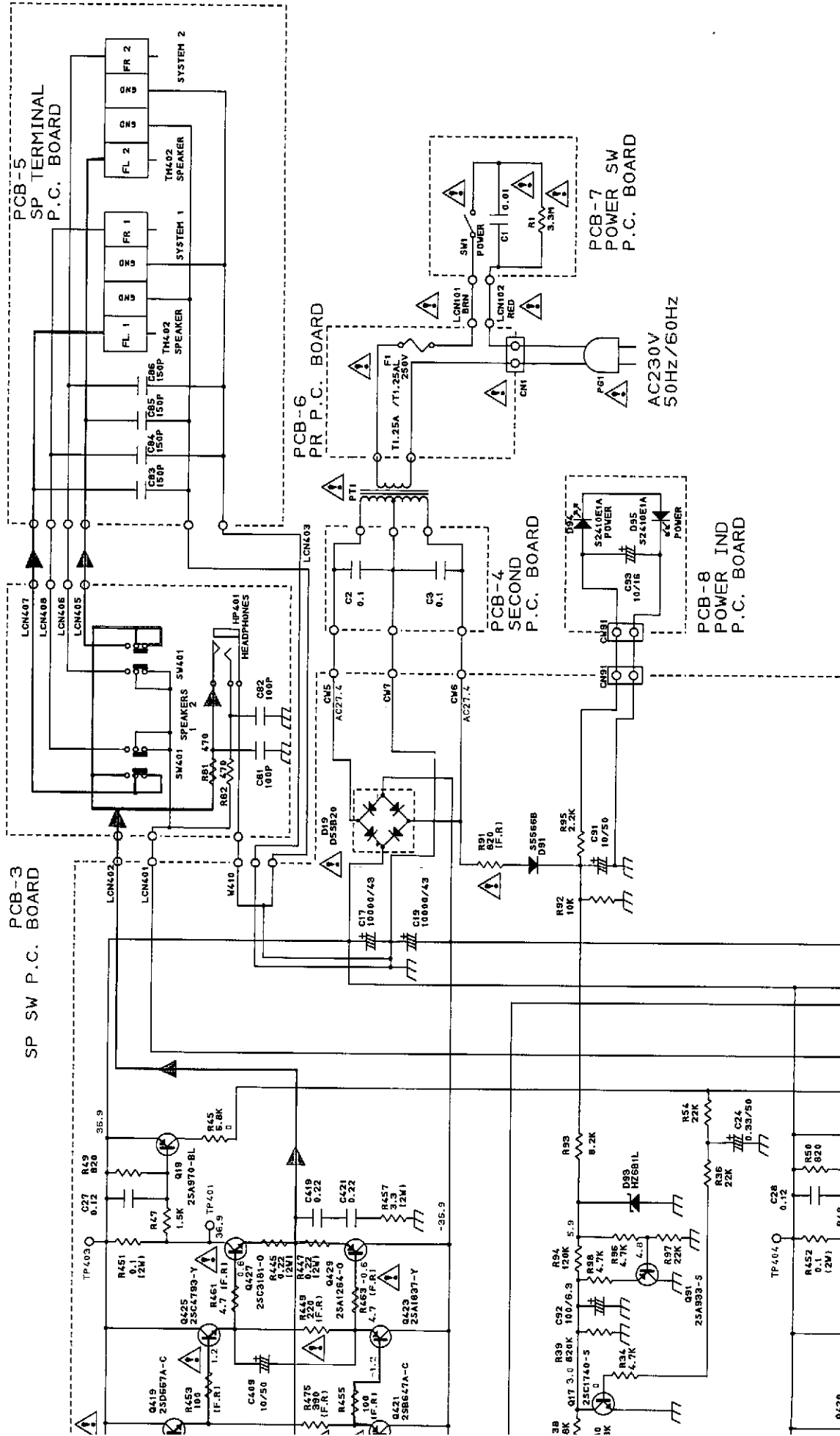

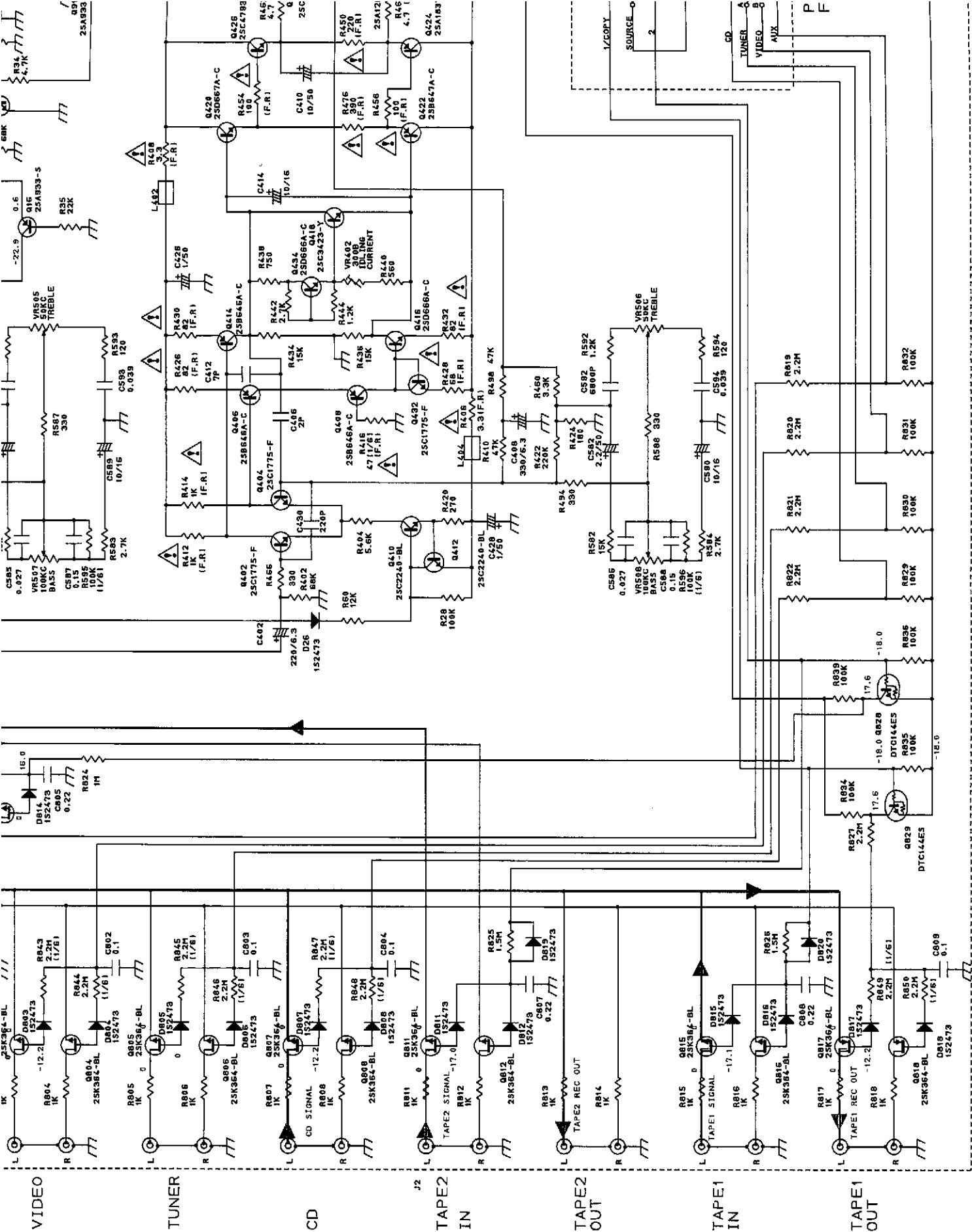

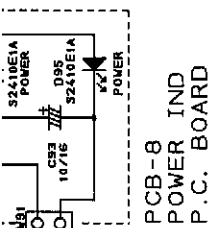

PCB-8
POWER IND
P.C. BOARD

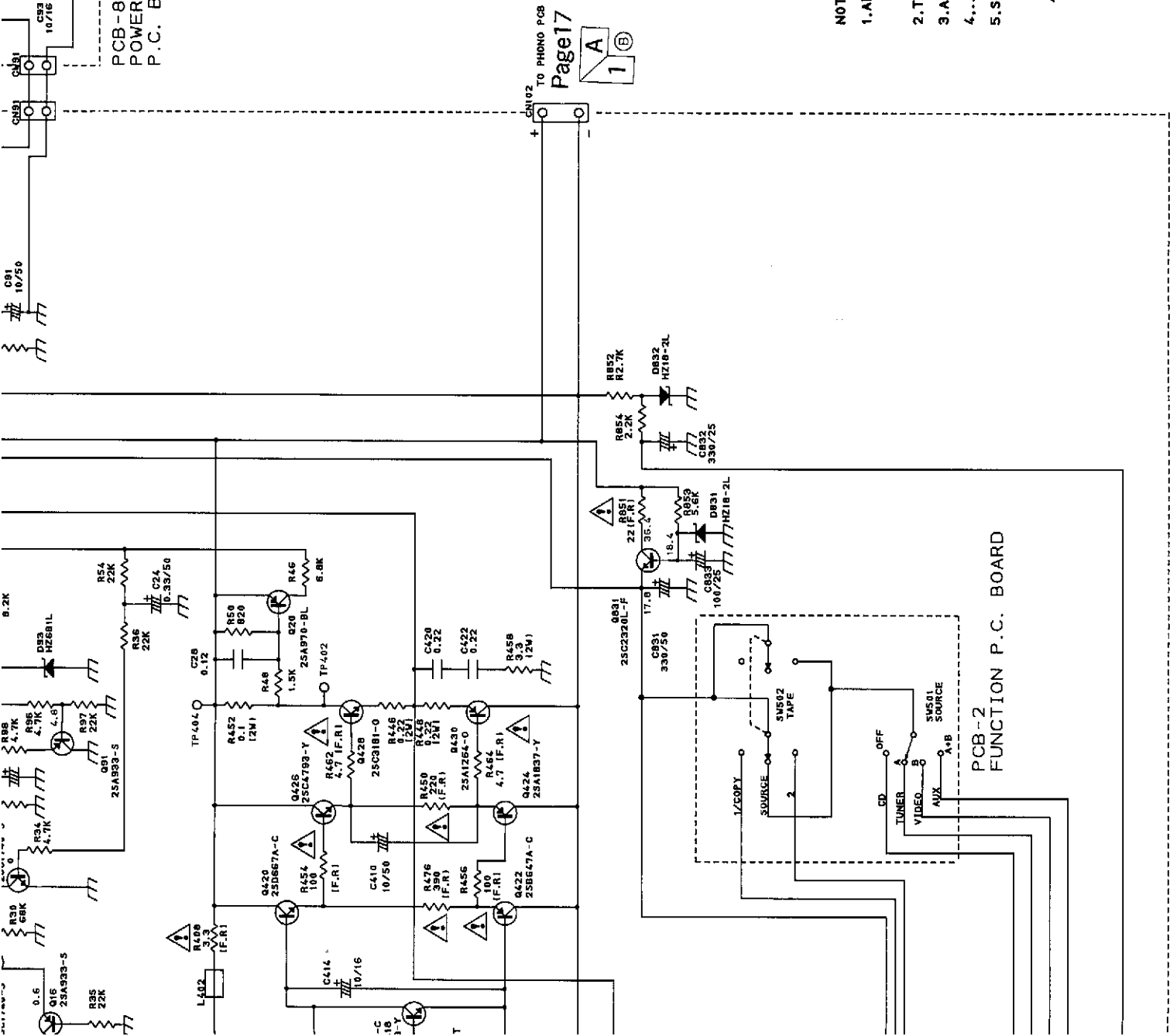

TO PHONO PCB
Page 17

NOTE

1. ALL RESISTANCE VALUES ARE IN ohm
Kohm=1000ohm, Mohm=1000Kohm.
2. THE WATTAGE OF RESISTORS IS 1/4W UNLESS OTHERWISE NOTED.
3. ALL CAPACITANCE VALUES ARE IN uF UNLESS OTHERWISE NOTED. P=uuF.
4. ...V:DC VOLTAGE AT NO SIGNAL UNLESS OTHERWISE NOTED.
5. SAFETY REQUIREMENTS COMPONENTS IN ACCORDANCE WITH PRESENT

SAFETY REGULATIONS. THESE COMPONENTS MUST ONLY BE REPLACED BY ORIGINAL PARTS.



PCB-2
FUNCTION P.C. BOARD